

Recommended PCB Layout(Top View)

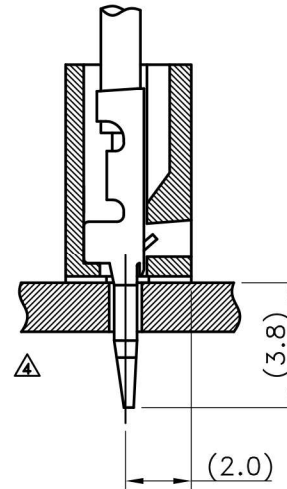

Mated Drawing (REF.)

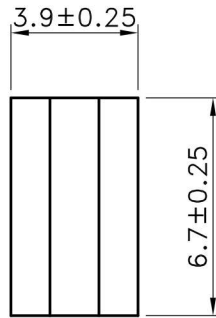
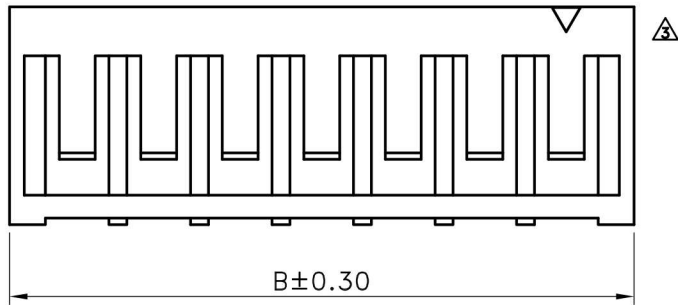
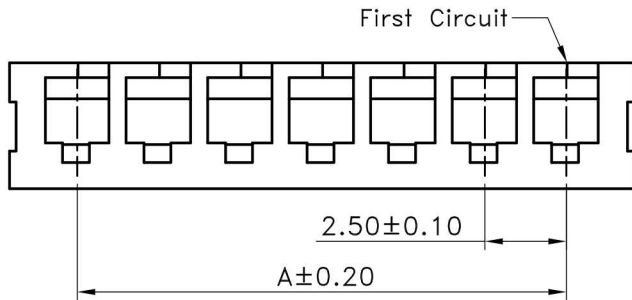
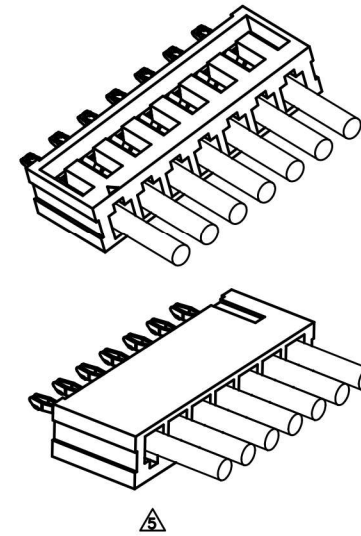

- SPECIFICATIONS ⚠
 - Current Rating : 3A AC/DC
 - Withstanding Voltage : 800V AC/minute
 - Insulation Resistance : 1000M Ω min
 - Temperature Range : - 40°C to + 105°C ⚠
 - Contact Resistance : 10m Ω max

- HOUSING ⚠ ⚠
 - Part No. : JS-1137-XX XX

- ① Poles: 2~16
- ② Base Color
 - Blank: Brown
 - W: White
 - R: Red
 - BK: Black ⚠
- Material : Nylon 66 UL94-V0
- Q' ty : 1000 pcs./Bag

Poles	Dimensions(mm)	
	A	B
2	2.50	6.50
3	5.00	9.00
4	7.50	11.50
5	10.00	14.00
6	12.50	16.50
7	15.00	19.00
8	17.50	21.50
9	20.00	24.00
10	22.50	26.50
11	25.00	29.00
12	27.50	31.50
13	30.00	34.00
14	32.50	36.50
15	35.00	39.00
16	37.50	41.50



喬訊電子工業股份有限公司
CHYAO SHIUNN
ELECTRONIC INDUSTRIAL LTD.

PART NO JS-1137-XXXX
2.50mm Board-In Type Connector, Straight

APPROVED BY	SCALE	UNIT	TOLERANCE	LTR	REVISION RECORD	NAME	DATE	LTR	REVISION RECORD	NAME	DATE
張育瑞		mm	.0 ±0.30	⚠	圖面遺失	余秀麗	2005/05/15	⚠	修改溫度範圍	林宛盈	2017/01/05
CHECKED BY	PROJ	VER NO.	.00 ±0.20	⚠	物性表修改	劉蓮花	2007/04/06	⚠	增加黑色規格選項	謝君	2022/03/25
劉娜		a9	.000 ±0.10	⚠	圖面與實物不符	簡海平	2007/08/15	⚠			
			ANGLE		增加互配圖; 修改物性表	黃科員	2008/10/08				
DRAWN BY	DATE	SIZE	0° ±1°	⚠	增加3D View	林豐盛	2011/02/14				
謝君	2022/03/25	A4	.0° ±	⚠	物性表修改	王誠賢	2011/07/13				
			SHEET	1/1	增加紅色料號選項	譚玉華	2016/03/17				

CUSTOMER
Conforms to The RoHS Instruction

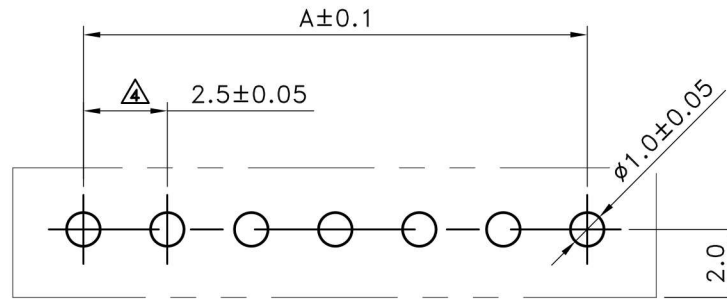
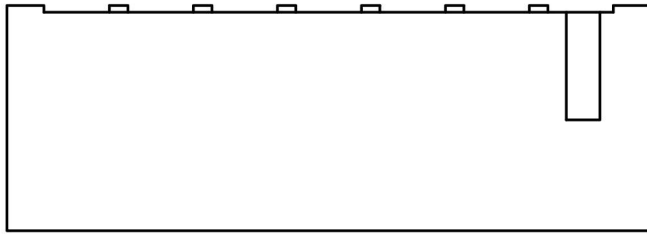

Recommended PCB Layout(Top View)

■ SPECIFICATIONS

- Voltage Rating : 250V AC/DC
- Current Rating : 3A AC/DC
- Withstanding Voltage : 800V AC/minute
- Insulation Resistance : 1000M Ω min
- Temperature Range : - 25°C to + 85°C
- Contact Resistance (On Crimped Portion) : 10mΩ max

■ HOUSING

- Part No. : JS-1137B-XX X
- Code No : ① ②
- ① Poles: 2-16 (Board in ; Straight)
- ② Base Color :
Blank : Nature
W : White
- Material : Nylon 66 UL94-V0
- Q' ty : 1000 pcs./Bag

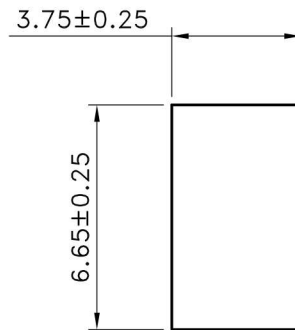
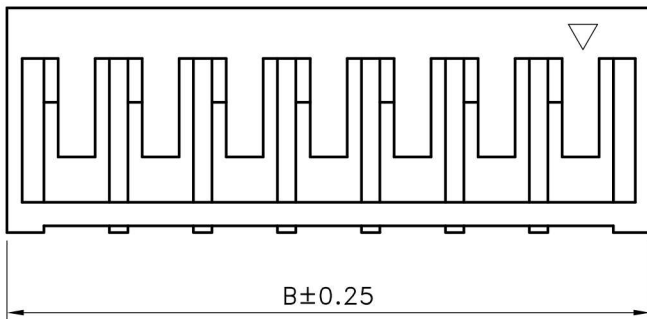
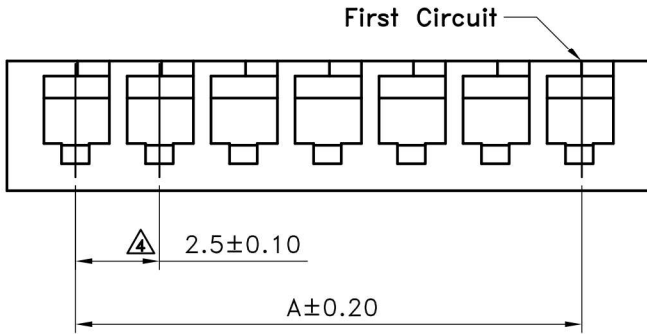

Mated Drawing (REF.)

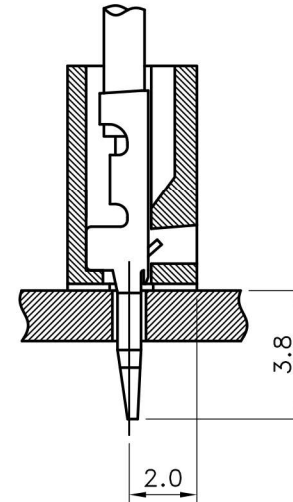

Poles	Dimensions(mm)	
	A	B
2	2.50	6.50
3	5.00	9.00
4	7.50	11.50
5	10.00	14.00
6	12.50	16.50
7	15.00	19.00
8	17.50	21.50
9	20.00	24.00
10	22.50	26.50
11	25.00	29.00
12	27.50	31.50
13	30.00	34.00
14	32.50	36.50
15	35.00	39.00
16	37.50	41.50



喬訊電子工業股份有限公司
CHYAO SHIUNN
ELECTRONIC INDUSTRIAL LTD.

PART NO JS-1137B-XXX
2.50mm Crimp Style Connectors Housing

APPROVED BY	SCALE	UNIT	TOLERANCE	LTR	REVISION RECORD	NAME	DATE	LTR	REVISION RECORD	NAME	DATE
張育瑞		mm	.0 ±0.30	△	ECR 200708-001	余秀麗	2007/08/06	△			
CHECKED BY	PROJ	VER NO.	.00 ±0.20	△	ECR 200708-020	黃科源	2007/08/20	△			
黃科源		a	.000 ±0.10	△	ECR 200810-002	黃科源	2008/10/22	△			
DRAWN BY	DATE	SIZE	ANGLE		增加白色選項, 更新圖框	吳弘文	2013/08/12		CUSTOMER		
吳弘文	2013/03/07	A4	0° ±1°	△					Conforms to The RoHS Instruction		
			±	△							
			SHEET	1/1							

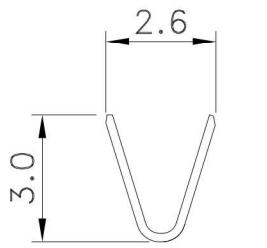
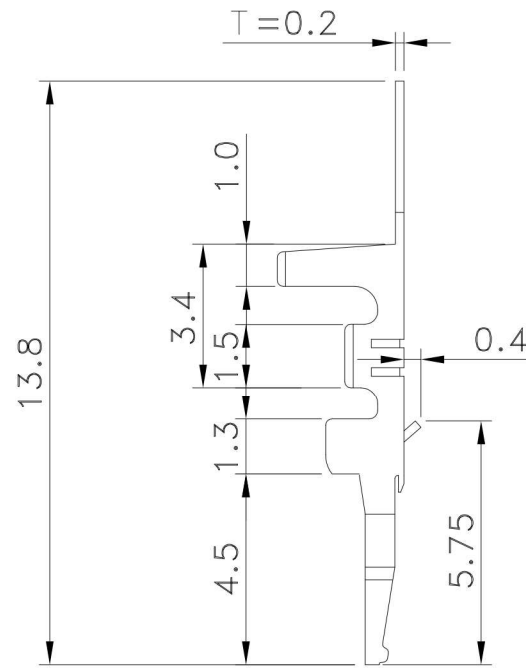
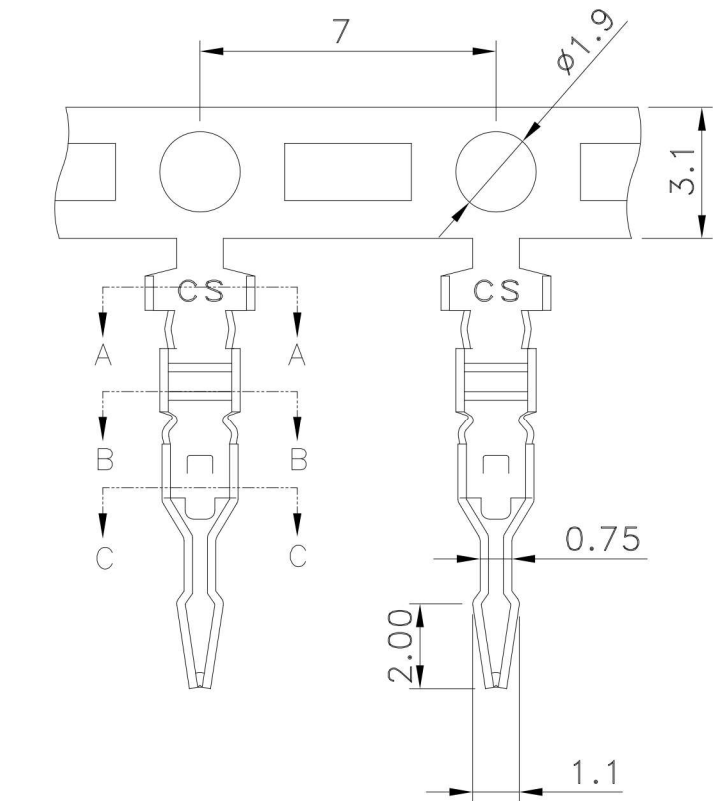

△ SEC A-A

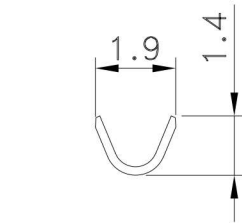

△ SEC B-B

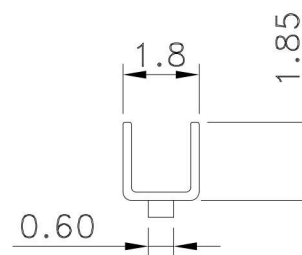

△ SEC C-C

■ SPECIFICATIONS

- Voltage Rating : 250V AC, DC
- Current Rating : 2.5A AC,DC.

- Withstanding Voltage : 800V AC/minute
- Insulation Resistance : 1000MΩ min
- Temperature Range : - 40°C to + 105°C △4
- Contact Resistance : 20mΩ max.

■ TERMINAL

- Part No. : JS-1137B-TXX

① B: Stamping after Tin plated

BP: Stamping before Tin Plated

- Applicable Wires:AWG#22-28
- Material : Brass
- Finished : Tin plated
- Thickness : 0.2mm
- Q' ty : 10.000 pcs./Reel

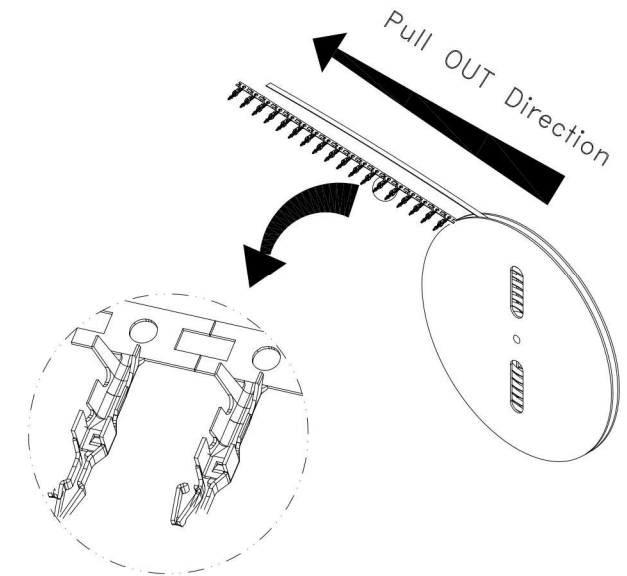

△

 喬訊電子工業股份有限公司 CHYAO SHIUNN ELECTRONIC INDUSTRIAL LTD.	APPROVED BY	SCALE	UNIT	TOLERANCE	LTR	REVISION RECORD	NAME	DATE	LTR	REVISION RECORD	NAME	DATE
	Tom		mm	.0 ±0.30 △1	XXX	XXX	XXX	XXXX/XX/XX	△8			
PART NO JS-1137B-TXX 2.50mm Crimp Style Connectors Terminal	CHECKED BY	PROJ	VER NO.	.00 ±0.20 △2	XXX	更新圖框，增加捲繞方向圖	吳弘文	2014/10/17	△9			
	Erin		a4	.000 ±0.10 △3	修改溫度範圍	林宛盈	2017/01/05	△10				
	DRAWN BY	DATE	SIZE	ANGLE						CUSTOMER		
	Ying	2017/01/05	A4	0° ±1° △5						Conforms to The RoHS Instruction		
				.0° ± △6								
				SHEET 1/1 △7								

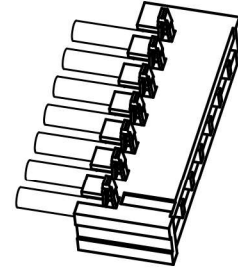
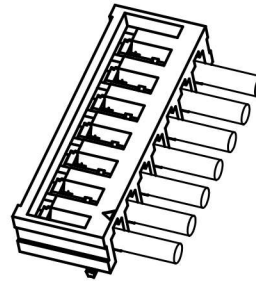
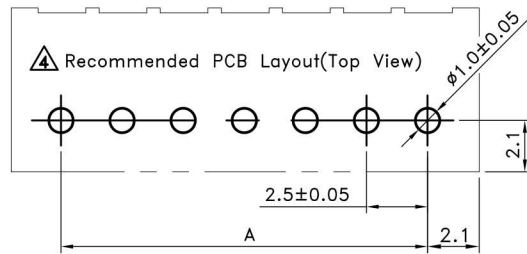

3D VIEW

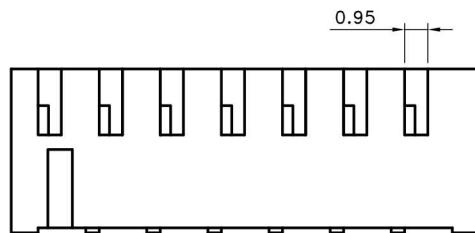
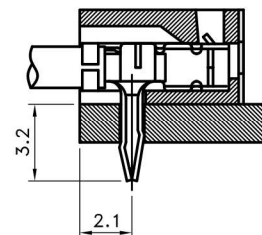
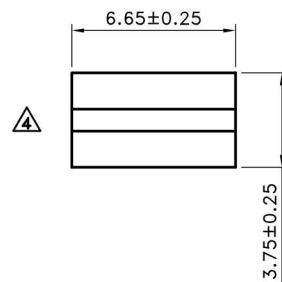
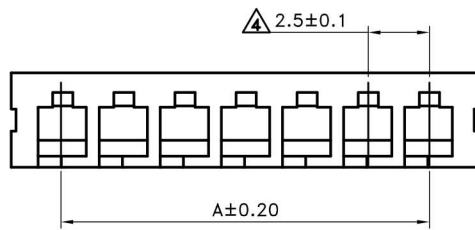
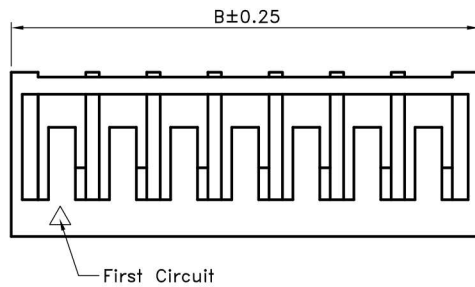

SPECIFICATIONS

- Current Rating : 3A AC/DC
- Withstanding Voltage : 800V AC/minute
- Insulation Resistance : 1000MΩ min
- Temperature Range : - 25°C to + 85°C
- Contact Resistance (On Crimped Portion) : 10mΩ max

HOUSING

- Part No. : JS-1137R-XX(XX)

①

- ① Material: BLANK :Nylon 66 UL94-V0
GW : Nylon 66 UL94V-0(Glow Wire)
- Poles : 2-16 (Board in ; Right Angle)
 - Q' ty : 1000 pcs./Bag

Poles	Part No.	Dimensions(mm)	
		A	B
2	JS-1137R-02	2.50	6.50
3	JS-1137R-03	5.00	9.00
4	JS-1137R-04	7.50	11.50
5	JS-1137R-05	10.00	14.00
6	JS-1137R-06	12.50	16.50
7	JS-1137R-07	15.00	19.00
8	JS-1137R-08	17.50	21.50
9	JS-1137R-09	20.00	24.00
10	JS-1137R-10	22.50	26.50
11	JS-1137R-11	25.00	29.00
12	JS-1137R-12	27.50	31.50
13	JS-1137R-13	30.00	34.00
14	JS-1137R-14	32.50	36.50
15	JS-1137R-15	35.00	39.00
16	JS-1137R-16	37.50	41.50



喬訊電子工業股份有限公司
CHYAO SHIUNN
ELECTRONIC INDUSTRIAL LTD.

PART NO JS-1137R-XX(XX)

2.50mm Crimp Style Connectors

APPROVED BY	SCALE	UNIT	TOLERANCE	LTR	REVISION RECORD	NAME	DATE	LTR	REVISION RECORD	NAME	DATE
張育瑞		mm	.0 ±0.30		ECR RoHS Compliant	余秀麗	07/01/04				
CHECKED BY	PROJ	VER NO.	.00 ±0.20		ECR DG 200712-005	簡海平	07/12/15				
簡子欽		a5	.000 ±0.10		ECR 200810-002	黃科源	08/10/22				
DRAWN BY	DATE	SIZE	ANGLE		ECR 201102-007	林豐盛	11/02/14	CUSTOMER			
周家慶	2017/10/26	A4	0° ±1°		新增GW材質	周家慶	17/10/26				
			0° ±					Conforms to The RoHS Instruction			
			SHEET 1/1								

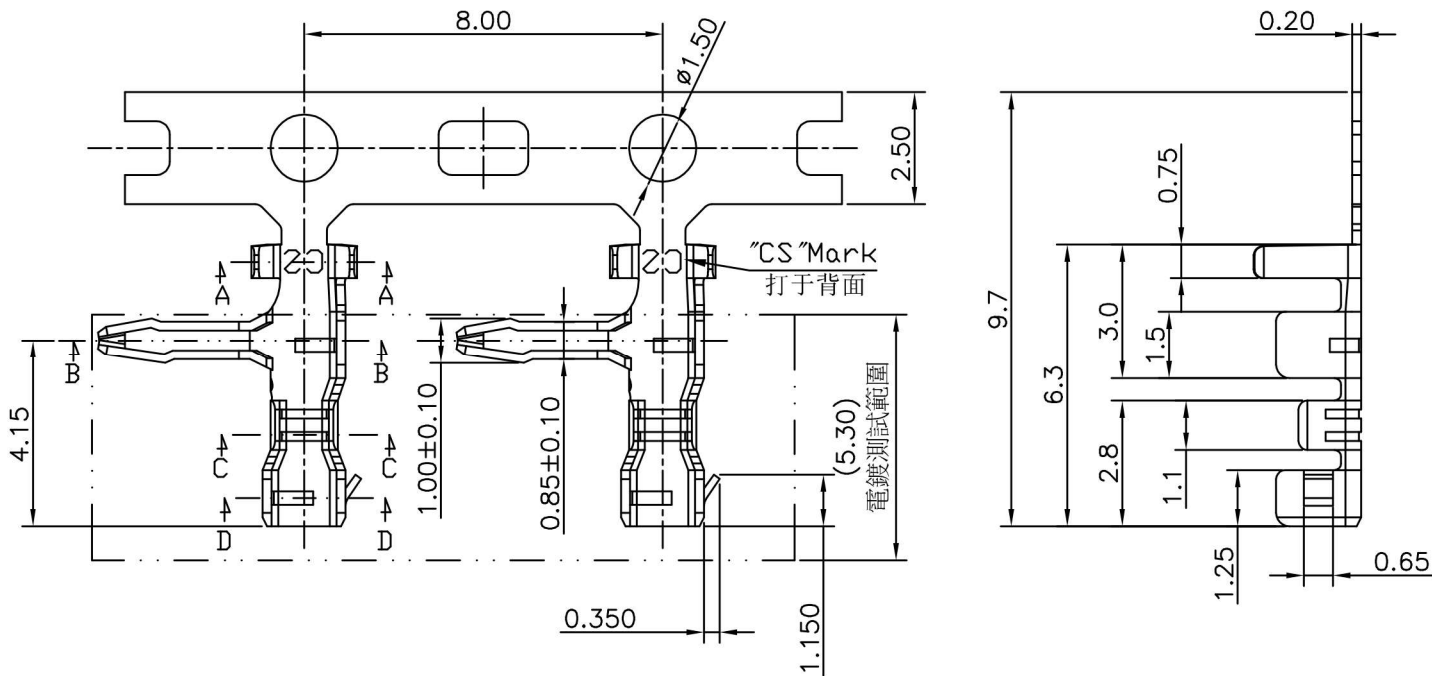

- ▲ SPECIFICATIONS**
- Voltage Rating : 250V AC/DC
 - Current Rating : 3A AC/DC
 - Withstanding Voltage : 800V AC/minute
 - Insulation Resistance : 1000MΩ min
 - Temperature Range : - 25°C to + 85°C
 - Contact Resistance : 10mΩ max

▲ TERMINAL
 Part No. : JS-1137R-TXX
 Ordering Code ①

- ▲ ① Material&Stamping :**
- Blank: Phos. Bronze , Stamping after Plating
 - P: Phos. Bronze, Stamping before Plating
 - B: Brass, Stamping after Plating
 - BP: Brass, Stamping before Plating
- Applicable Wires : AWG#22-28
 - Material : Refer the above options
 - Finish :
- QJS-1137R-T:80u" min.TIN over 15u" min. NICKEL
 QJS-1137R-TP:120u" min.TIN over 30u" min. NICKEL
 QJS-1137R-TB:80u" min.TIN over 15u" min. NICKEL
 QJS-1137R-TBP:120u" min.TIN over 30u" min. NICKEL
- Thickness : 0.2 mm
 - Q' ty : 10000 pcs./Reel

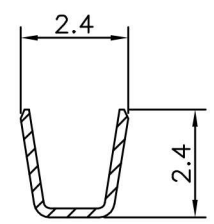

A-A SEC

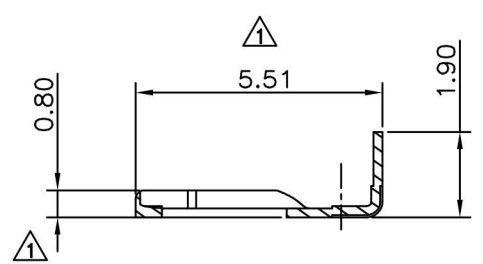

B-B SEC

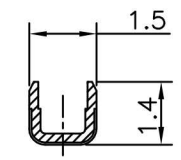

C-C SEC

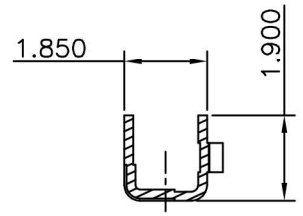

D-D SEC

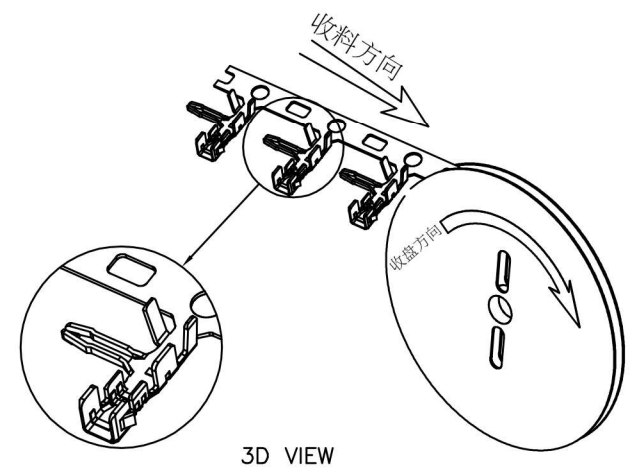

3D VIEW

喬訊電子工業股份有限公司
 CHYAO SHIUNN
 ELECTRONIC INDUSTRIAL LTD.

APPROVED BY	SCALE	UNIT	TOLERANCE	LTR	REVISION RECORD	NAME	DATE	LTR	REVISION RECORD	NAME	DATE
Tom Shih	1:1	mm	.0 ±0.30	▲	修改尺寸公差及修改物性表	黃廣珍	13/8/19	▲			
CHECKED BY	PROJ	VER NO.	.00 ±0.20	▲	取消球標1中重複T編碼	Erin	2021/10/26	▲			
			.000 ±0.10	▲				▲			

PART NO JS-1137R-TXX

DRAWN BY	DATE	SIZE	ANGLE	LTR	CUSTOMER
Tom Shih		a2	0° ±1°	▲	
Erin Chou	2021/10/26	A4	.0° ±	▲	

2.50mm Board in Connectors Terminal

SHEET	1/1	LTR	Conforms to The RoHS Instruction
		▲	