

REV.	ECN.NO	REVISIONS	REV.DRAWN	DATE
A	----	筛料口加深	Zhangqiang	2019.12.13
B	----	图面更新	Zhangqiang	2020.04.14
C	----	图面更新	Caiqiang	2021.02.02

HOUSING:

- 1. Material:
PA66, UL94V-0
- 2. Part No.:
JS-2512-XXK-XXXX

Poles: See Note 1

Blank: PA66+15%GF 750° GW

- Blank: Natural
- RD: Rad
- BU: Blue
- YW: Yellow

- 3. Halogen free product identification LOGO on the packing
- 4. Packing : 200pcs/Bag

Note 1:

孔位	尺寸			
	Dim A	Dim B	Dim C	Dim D
2	2.50	/	5.90	7.50
3	5.00	6.65	8.40	10.00
4	7.50	7.75	10.90	12.50
5	10	10.25	13.4	15
6	12.50	9.05	15.90	17.50
7	15	9.05	18.4	20
8	17.5	11.55	20.9	22.5

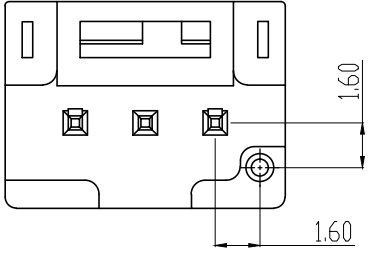
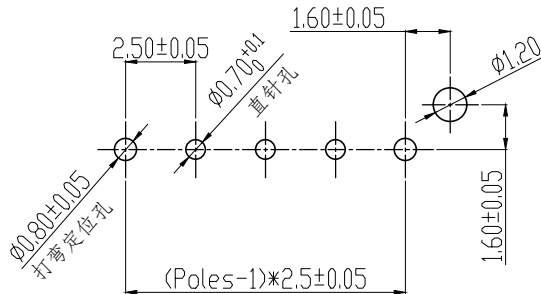
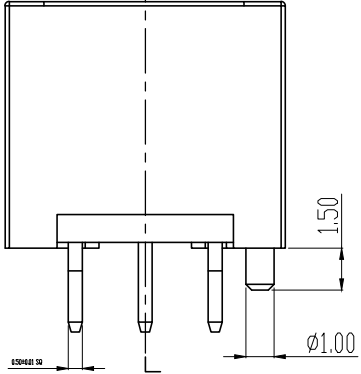
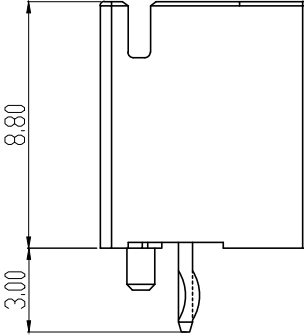
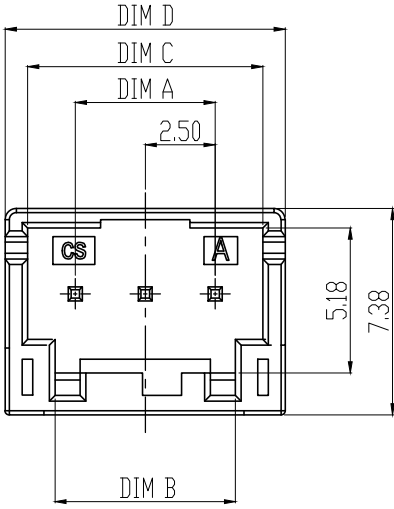
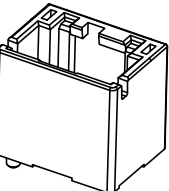

X. ±0.40	X.* ±5.0'	UNITS mm	NAME(INTENDED USE)	乔讯电子(上海)有限公司 CHYAO SHUINN ELECTRONICS(SHANGHAI)CO.,LTD.
.X ±0.30	.X' ±2.0'	MAT'S	CUSTOMER	
.XX ±0.20	.XX' ±1.0'	SEE NOTE	PART NO.(INTENDED USE)	TITLE:
.XXX ±0.10	---	FINISH	JS-2512-XX	2.50mm Pitch Crimp Terminal
THESE DRAWINGS AND SPECIFICATIONS ARE THE PROPERTY OF CHYAO SHUINN ELECTRONIC CO.,LTD.AND SHALL NOT BE REPRODUCED, COPIED OR USED IN ANY MANNER WITHOUT THE PRIOR WRITTEN CONSENT OF CHYAO SHUINN ELECTRONIC CO.,LTD.			APPV'D	DWG NO.
Q'TY			CHK'D	020-XXXX-2512-XX
DR': YangSong 2019.03.14			SCALE	SHEET
			4:1	1/2
			REV	/

符合环境管理物质



REV.	ECN.NO	REVISIONS	REV.DRAWN	DATE
A	----	筛料口加深	Zhangqiang	2019.12.13
B	----	图面更新	Zhangqiang	2020.04.14
C	----	图面更新	Caiqiang	2021.02.02

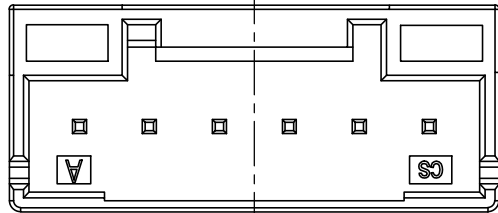

JS-2512-06K-RD

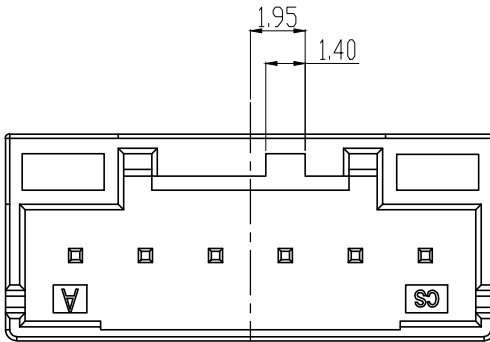

JS-2512-06K

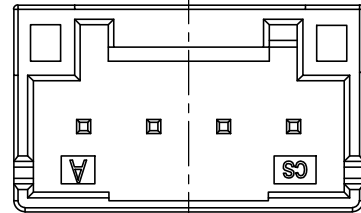

JS-2512-04K-YW

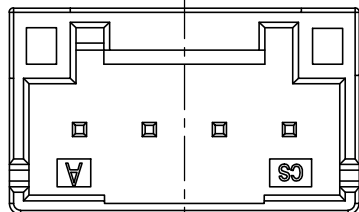

JS-2512-04K-RD

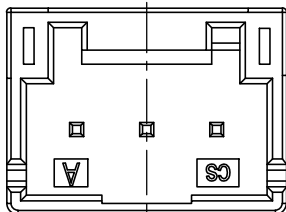

JS-2512-03K-YW

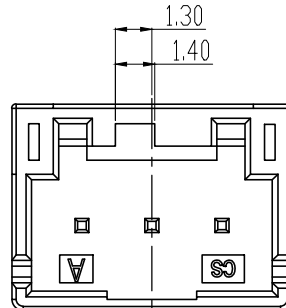

JS-2512-03K-BU

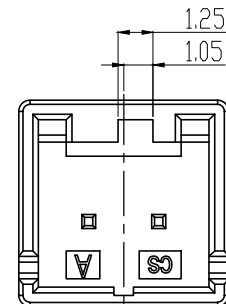

JS-2512-02K

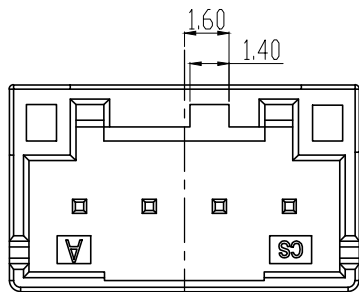

JS-2512-04K

X.	±0.40	X.*	±5.0'	UNITS	mm	NAME(INTENDED USE)	乔讯电子(上海)有限公司 CHYAO SHUNN ELECTRONICS(SHANGHAI)CO.,LTD.
.X	±0.30	.X'	±2.0'	MAT'S		CUSTOMER	
.XX	±0.20	.XX'	±1.0'	SEE NOTE		PART NO.(INTENDED USE)	TITLE:
.XXX	±0.10	---	---	FINISH		JS-2512-XX	2.50mm Pitch Crimp Terminal
THESE DRAWINGS AND SPECIFICATIONS ARE THE PROPERTY OF CHYAO SHUNN ELECTRONIC CO.,LTD.AND SHALL NOT BE REPRODUCED, COPIED OR USED IN ANY MANNER WITHOUT THE PRIOR WRITTEN CONSENT OF CHYAO SHUNN ELECTRONIC CO.,LTD.						APPV'D	DWG NO.
						CHK'D	020-XXXX-2512-XX
						Q'TY	SCALE
						DR': YangSong 2018.12.10	SHEET
							REV
							4:1
							2/2
							/

符合环境管理物质

